

VELMAG® SURFACE DOUBLE ELECTROMAGNETIC LOCKS NF S 61-937 COMPLIANT

2 x 500 daN

- Integrated anti-disassemble device
- Satin aluminium housing
- Connection by screw terminal block
- Locked/unlocked status by HALL sensor (CTC model)
- Anti-remnance device by ejector



EF550-2

PRODUCT FEATURES

	12-24V DC		960-480 mA
	24V DC-2 A		42
	-10°C +55°C		2 x 500*

*Maximal theoretical holding forces, for an implementation meeting the optimum laying conditions



Suitable for double leaf doors

PV N° 13/2264/RG1 - LCPP

N° P-120001624.15

Item Code	Description	Weight in kg	Custom code
EF550-2	Surface double electromagnetic lock 2 x 500 DaN 12-24V DC	10	83014019
EF550-2CTC	Surface double electromagnetic lock 2 x 500 DaN 12-24V DC contact + LED	10	83014019

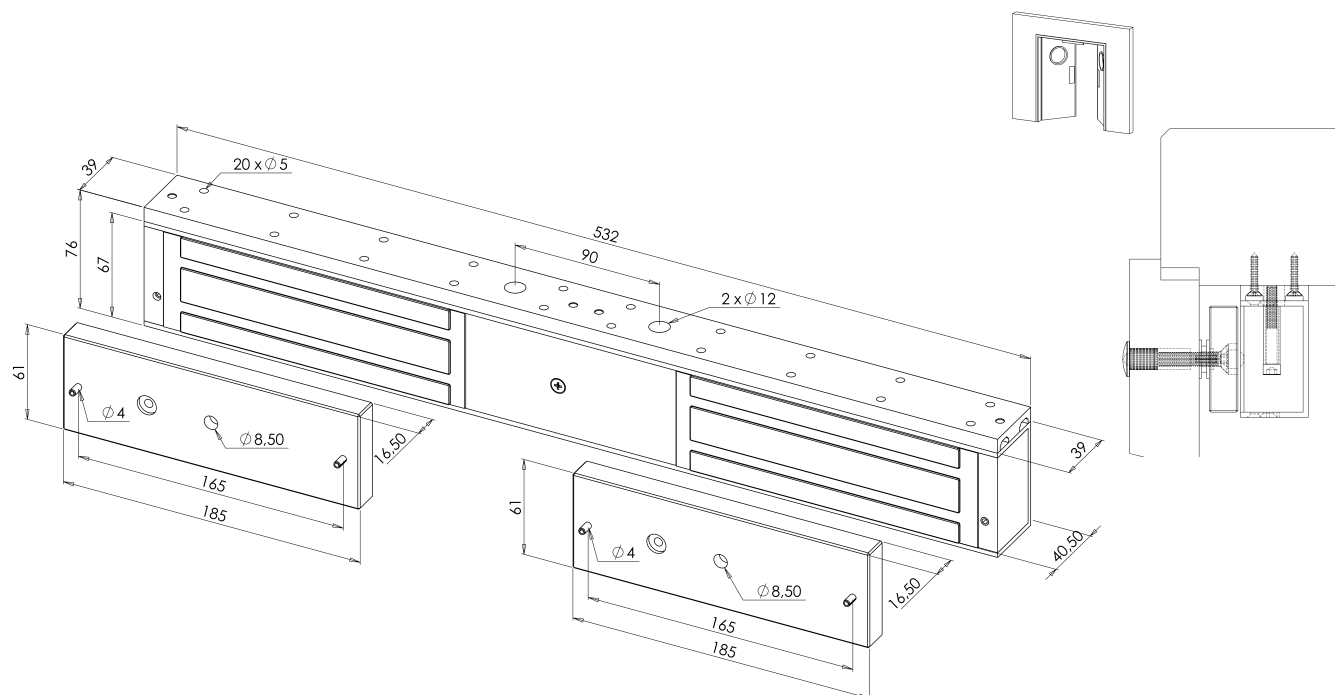

EF550-2

